



## AVK SERVICE CONNECTION VALVE, POM, PN16

### Tensile socket joint for PE pipes/external thread

16/29-010

AVK resilient seated service connection valves are designed with built-in safety in every detail. The wedge is vulcanized with AVK's own drinking water approved EPDM rubber compound. It features an outstanding durability due to the ability of the rubber to regain its original shape, the double bonding vulcanization process and the sturdy wedge design. The corrosion free materials and the high strength stem safeguard the unmatched reliability.

#### Product description:

POM service connection valve with AVK bonnet and socket end/external BSP thread. For drinking water and neutral liquids to max. 20°C. Note: The maximum working temperature is set according to the ISO9080 lifetime requirements for PE pipes, and is therefore not the max. temperature for the valve.

#### Standards:

- Designed according to EN 1074 part 1 & 2

#### Test/Approvals:

- Hydraulic test according to EN 1074-1 and 2 / EN 12266
- Seat: 1.1 x PN (in bar), Body: 1.5 x PN (in bar). Operation torque test
- Approved according to Swedish type approval 1352 certified by KIWA

#### Features:

- Friction welded body, bonnet and end adaptors of POM (Polyoxymethylene)
- Wedge of brass CW626N vulcanized with EPDM rubber – both brass and rubber certified for use in contact with drinking water– and shaped with guides and a special rubber profile ensuring low closing torques
- Stem of stainless steel with rolled threads providing high strength
- Stem sealing with NBR wiper ring and two EPDM O-rings
- Friction ring between bonnet and thrust collar and a notch in the stem prevent overtorque of the valve
- The push-in joint end is fitted with an EPDM sealing ring and a tension ring of POM

#### Accessories:

Handwheel, stem cap, extension spindle, street cover and tapping saddle.



Expect ... **AVR**

The designs, materials and specifications shown are subject to change without notice. To ensure correct installation and warranty coverage, please observe AVK's installation instructions.

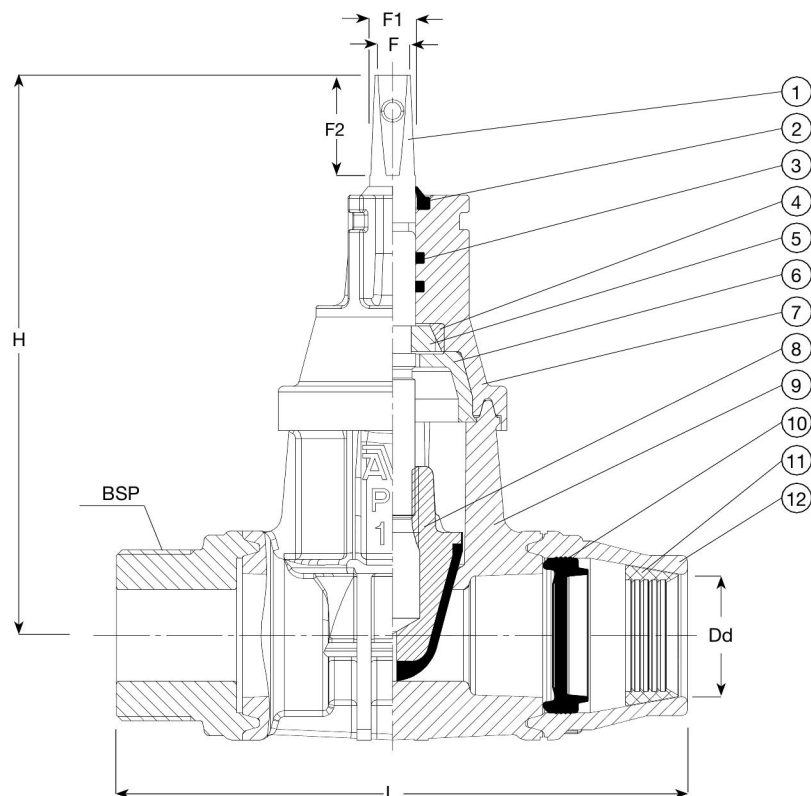

**Component list:**

1. Stem	Stainless steel 1.4104 (430F)	7. Bonnet	POM
2. Wiper ring	NBR rubber	8. Wedge	Brass, DZR CW626N with EPDM
3. O-ring	EPDM rubber	9. Body	POM
4. Friction ring	Stainless steel	10. Seal	EPDM rubber
5. Thrust collar	Brass, DZR CW602N	11. Tension ring	POM
6. Insert	PBT	12. End adaptor	POM

Components may be substituted with equivalent or higher class materials without prior notification.

**Reference nos. and dimensions:**

AVK ref. no.	DN	Dd	BSP	Product	L	H	F	F1	F2	Theoretical
	mm	mm	external	PN Class	mm	mm	mm	mm	mm	weight/kg
16-032-29-0603006	25	32	1 1/2"	PN16	199	180	12	15	35	1.4
16-040-29-0704006	32	40	2"	PN16	196	190	12	15	35	1.6
16-050-29-0804006	40	50	2"	PN16	238	203	12	15	35	2.4
16-063-29-0904006	50	63	2"	PN16	273	213	12	15	35	4.0